

# fab CONNECT her

Future Female  
Innovators In STEAM

## CONDUCTIVE DOUGH

LEÓN, 01.10.2024

**Partner:**

Fundación TMA - Fab Lab León

**Address :**

Avda. San Ignacio de Loyola, 177  
24191 San Andrés del Rabanedo (LEON), Spain

Co-funded by the  
Erasmus+ Programme  
of the European Union



# Electronic Circuits with Conductive Dough

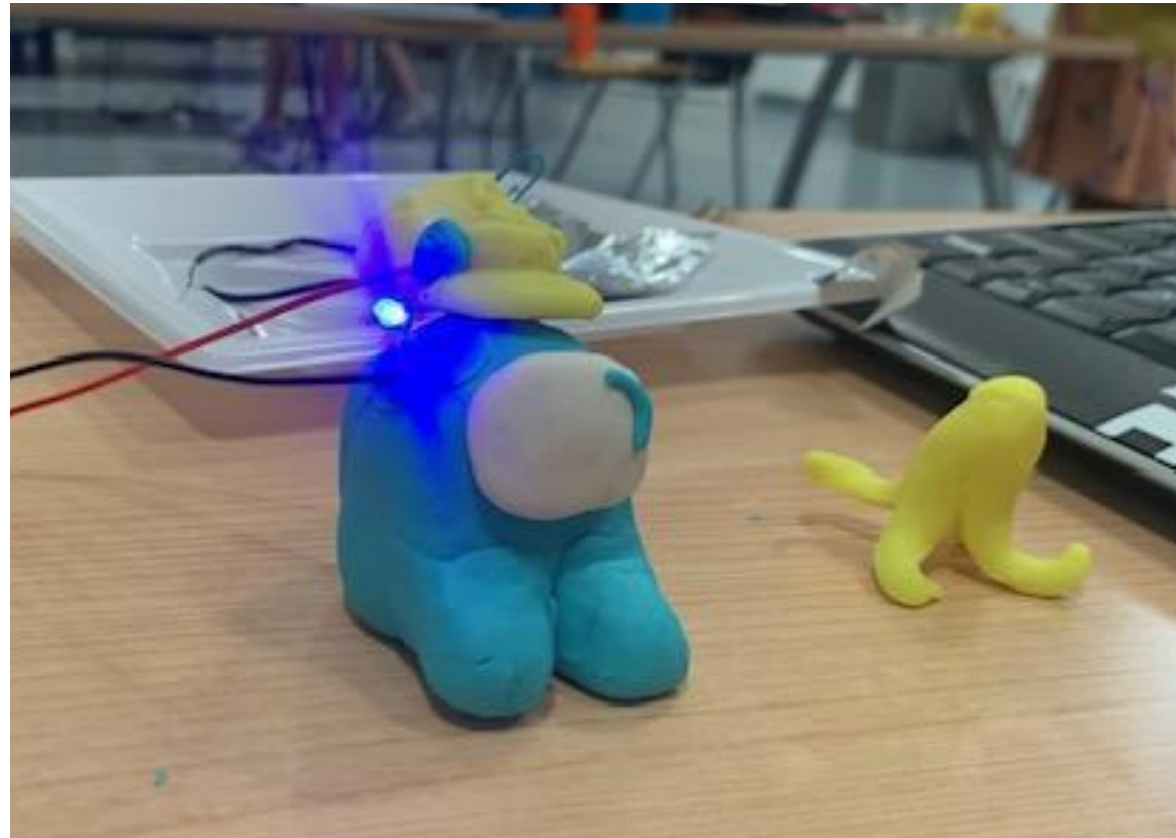

We will learn how to create electronic circuits with conductive dough to light up our characters.

## We will learn:

- The parts of an electric circuit.
- The difference between conductive and insulating materials.
- How to build a character using modeling dough.
- How to add lights to our character.

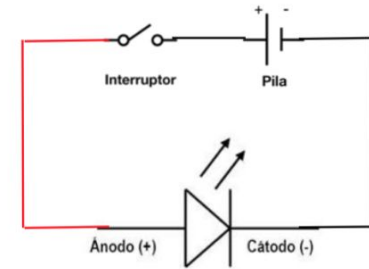

## Parts of a circuit:

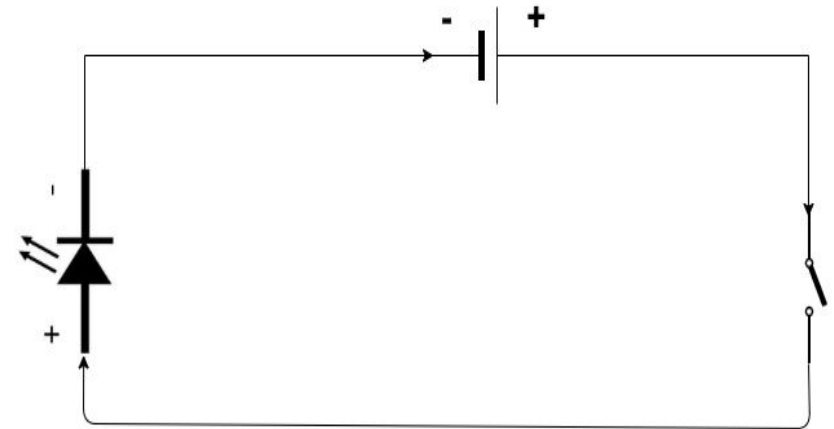
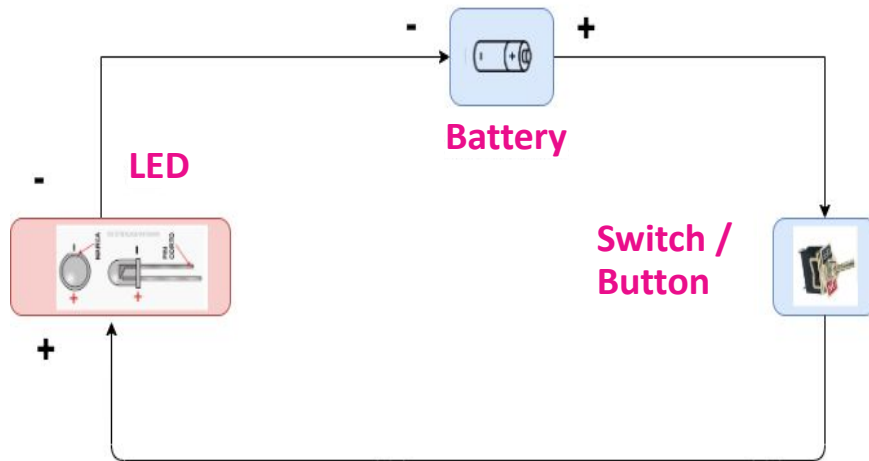

# List of materials:



9v Battery

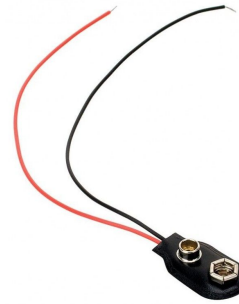

9v Battery Holder



LEDs



Jovi modelling dough  
(non conductive)



Conductive Dough

## Pay Attention:



- Never connect the two terminals of the battery directly to each other.
- Always cover the battery when not in use.



- The red and black wires of the connector, when attached to the battery holder, must never touch each other directly.

## Tip: Playdoh is conductive dough

**STEP 1: Make two Play-Doh bars approximately 8 cm long and fairly thick.**



**Tip: JOVI dough: It is an insulator.**

**STEP 2: Make a JOVI dough bar, longer and thicker than the other two.**



**Never connect the two pieces of Play-Doh together. This would cause a short circuit!!**



## Power source: The battery:

**STEP 3: Attach the battery holder to the battery, and connect the red wire (positive) to the battery using tape.**

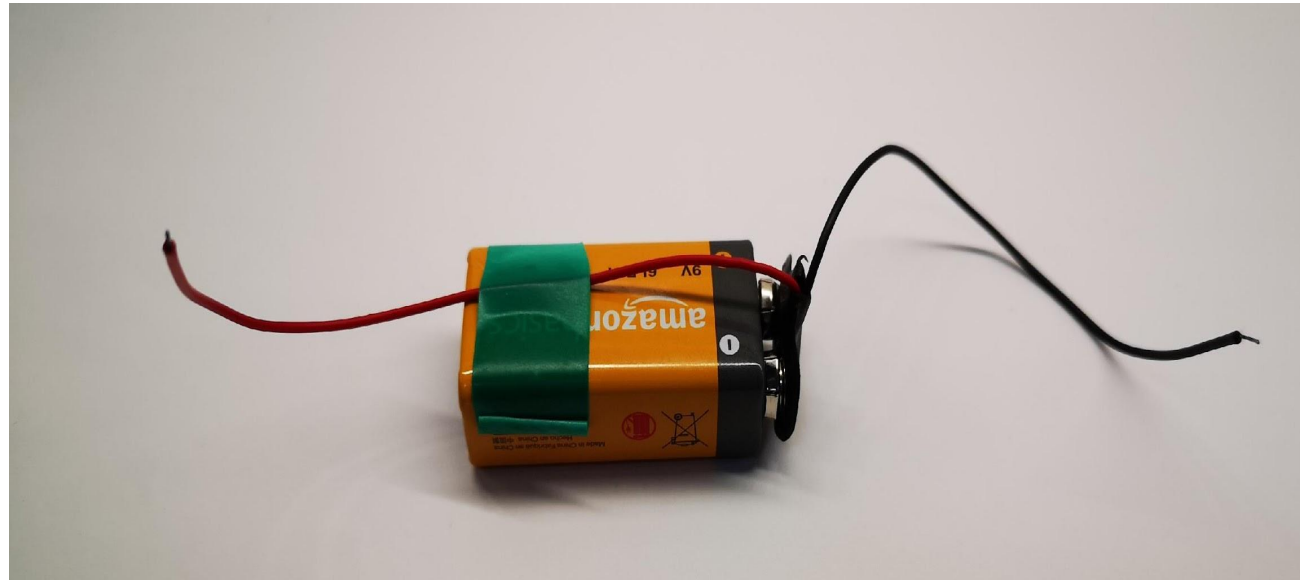

**The red and black wires of the connector, when attached to the battery holder, must never touch each other directly**

## Power source: The battery:

**STEP 4: Connect the battery wires, each to one of the conductive Play-Doh bars (pay attention to the color of the wires)**

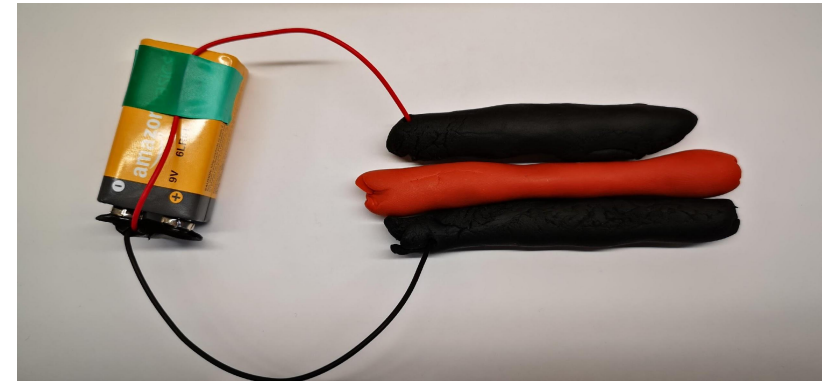
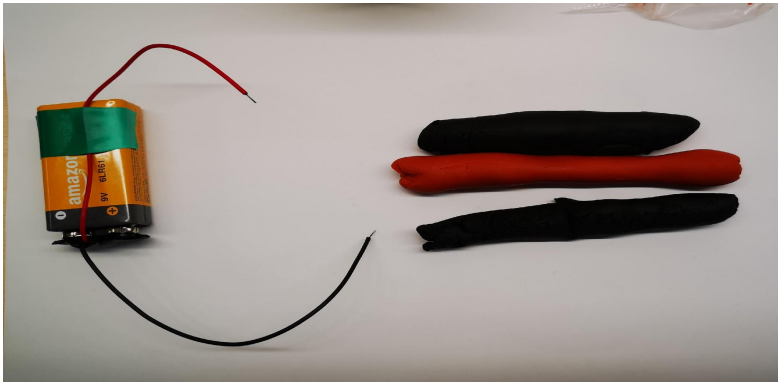

## Test the circuit:

STEP 5: Use the LED to test the circuit.

If you connect the positive leg of the LED to the Play-Doh connected to the red wire, and the other leg to the Play-Doh connected to the black wire, the LED should light up.

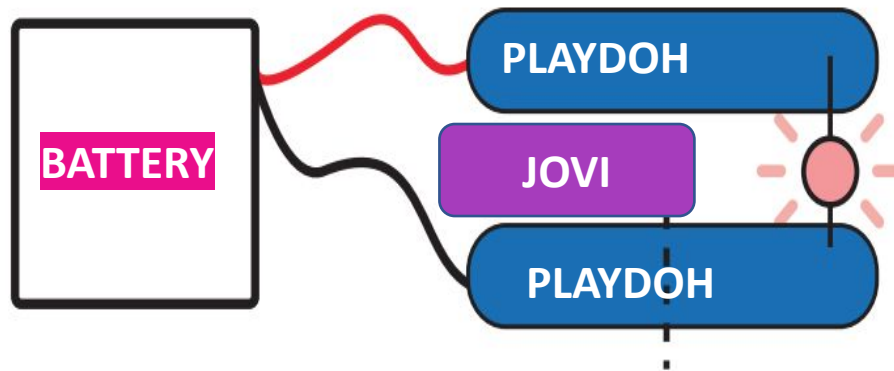

## LEARNING BY DOING:

Let's experiment with different materials to identify which ones **CONDUCT** electricity and which ones **DO NOT**.

## Materials that Conduct Electricity:

These are materials that allow the flow of electrical energy.

- Copper (e.g., wires)
- Aluminum (e.g., foil)
- Steel (e.g., paper clips)
- Graphite (e.g., pencil lead)
- Brass (e.g., keys)
- Silver and Gold (found in small electronic components)
- Conductive Play-Doh

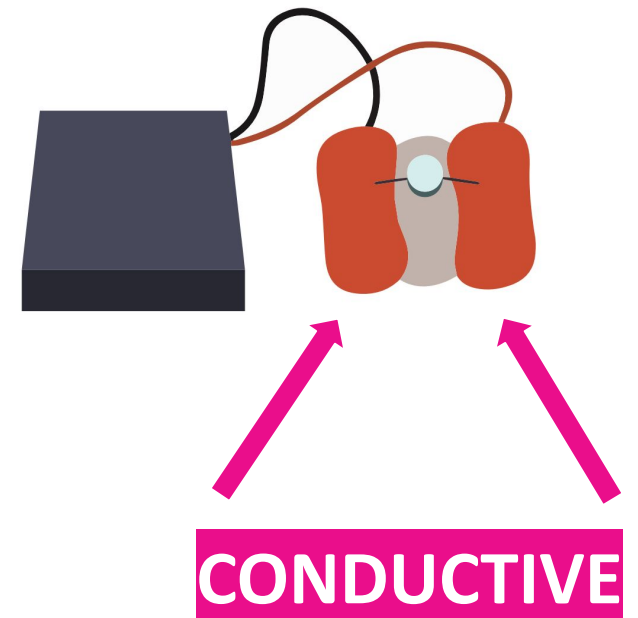

## Materials that Do Not Conduct Electricity:

Also called insulators, these are materials that hinder the flow of electrical energy.

- Plastic (e.g., bottle caps)
- Wood (dry)
- Rubber (e.g., erasers)
- Glass
- Ceramic
- Dry Paper
- Insulating Dough (e.g., JOVI dough)

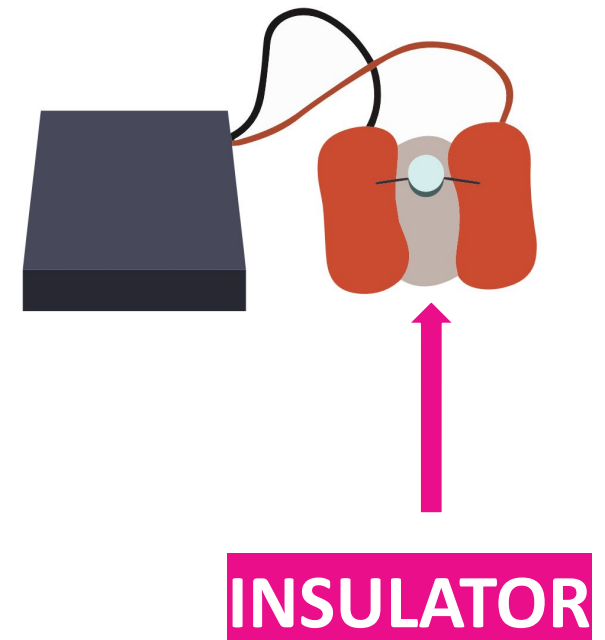

## Material Tester

### Materials Needed:

- A 9V battery with a holder.
- Conductive Play-Doh.
- An LED.
- Various materials to test (e.g., wood, plastic, foil, paper, etc.).

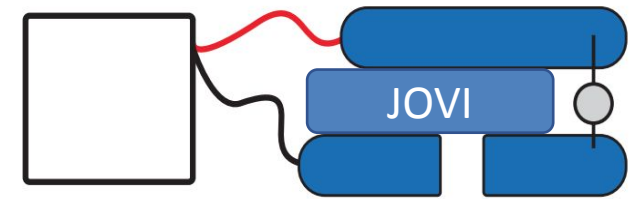

### Assemble the Circuit:

- Connect the battery wires to two separate pieces of conductive Play-Doh
- Insert one leg of the LED into the first piece of Play-Doh (or wire).
- Leave the other leg of the LED free, so it can touch the materials for testing.

### Testing Materials:

- Place one side of the material on the free Play-Doh.
- Touch the second side of the material with the free leg of the LED.

### Observation:

- If the LED lights up, the material is conductive.
- If it does not light up, the material is an insulator.

### Experiment with Various Materials:

- Test metals, plastics, fabrics, and other items to identify their properties.

## Material Tester:



The two Play-Doh bars must not touch each other.

Cut one of the conductive Play-Doh bars into two halves. The LED will stop lighting up because the circuit is now open.

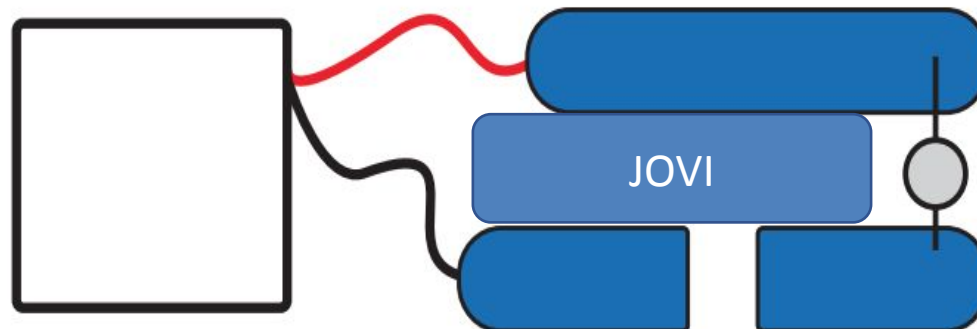



## Get to know the materials:

Test each material and classify it as either a **conductor** (allows electricity to pass through) or an **insulator** (blocks the flow of electricity).

To determine if a material is conductive, connect it between the two Play-Doh halves (1 and 2).

If the LED lights up, the material is **conductive**.

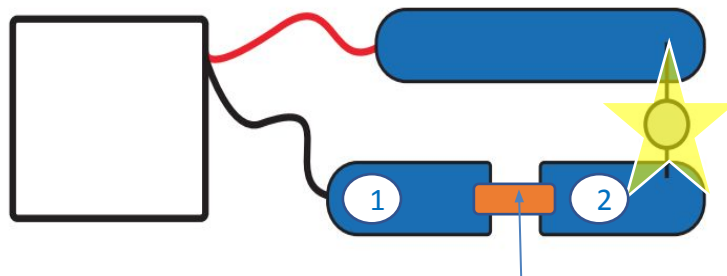

Conductive  
Material

If the LED does NOT light up, then the material is an **insulator**.

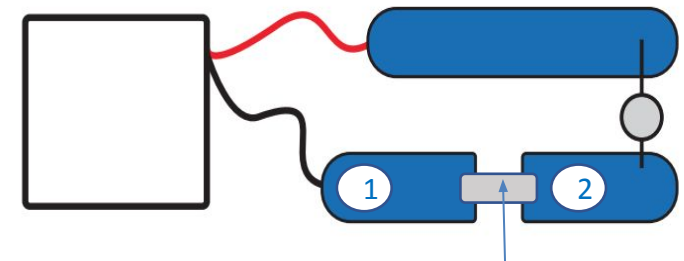





Insulator  
material

## It's Your Turn:

Test different materials by placing them between the two Play-Doh halves (1 and 2). Based on the results, classify them into **Insulators** and **Conductors**.

Create a Table :

| MATERIAL  | TYPE (INSULATOR / CONDUCTOR) |
|---|------------------------------|
|  ALUMINIUM FOIL        |                              |
|  PLASTIC THREADS      |                              |
|  PAINTED PAPER CLIPS |                              |
|  METAL PAPER CLIPS   |                              |

# LEARNING BY DOING:

Let's create a Safe System to Place an LED Inside Our Figure.

# LED CIRCUIT

Red Dough (JOVI): **INSULATOR**

Black Dough(Play Doh): **CONDUCTOR**

With the insulating dough (JOVI):

- Create a flat surface and a small ball.

With the conductive dough (Play-Doh):

- Create two small trunks.

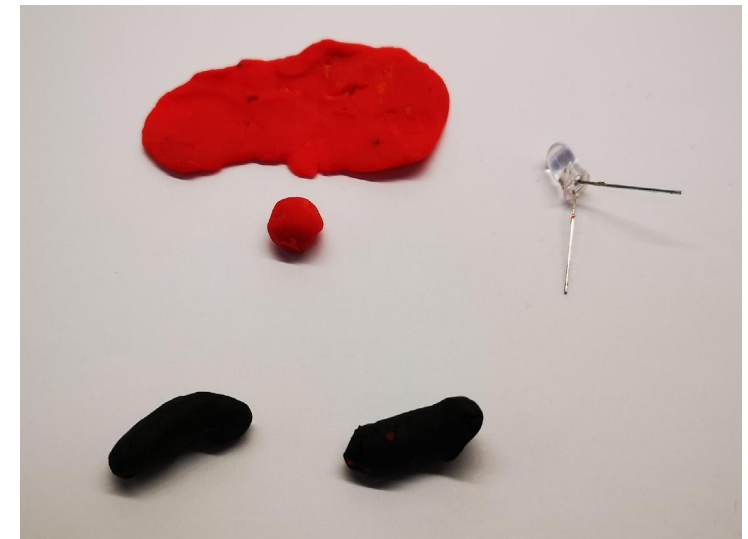

## LED CIRCUIT

Remember:

The two pieces of conductive Play-Doh must not touch each other.

To prevent this, place the two pieces of conductive Play-Doh (**black**) apart on top of the insulating Dough surface (**red**).

Then, place the small piece of insulating Dough (**red**) between the two conductive pieces to keep them separated and prevent them from touching. I trunks.

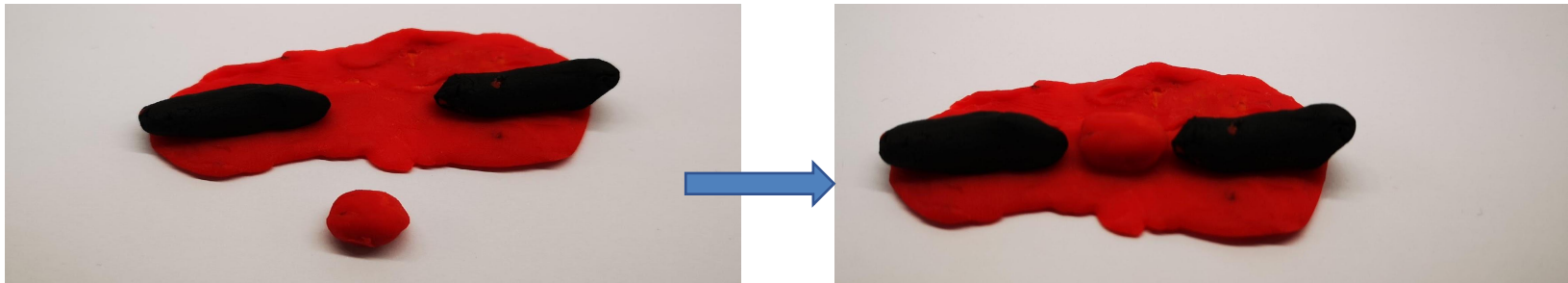

## LED CIRCUIT

Wrap everything inside the insulating dough surface.

Check first that the insulating Dough is doing its job: ensuring the conductive Play-Doh pieces do not touch each other. If you need to add more insulating Dough in the middle, do it now.

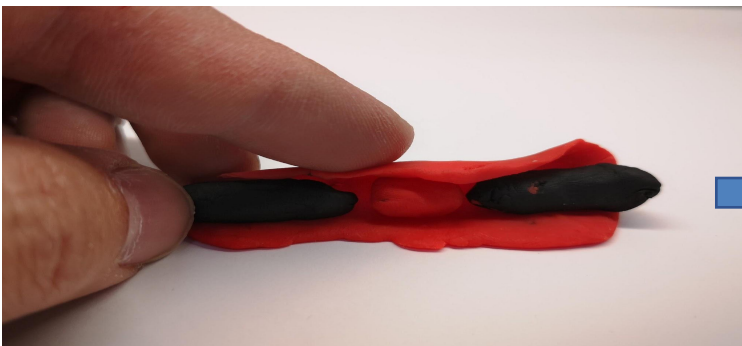

## LED CIRCUIT

Embed the LED, ensuring each leg reaches the conductive Play-Doh

Remember where you place the positive leg of the LED and where you place the negative leg. You can mark the Dough to keep track..

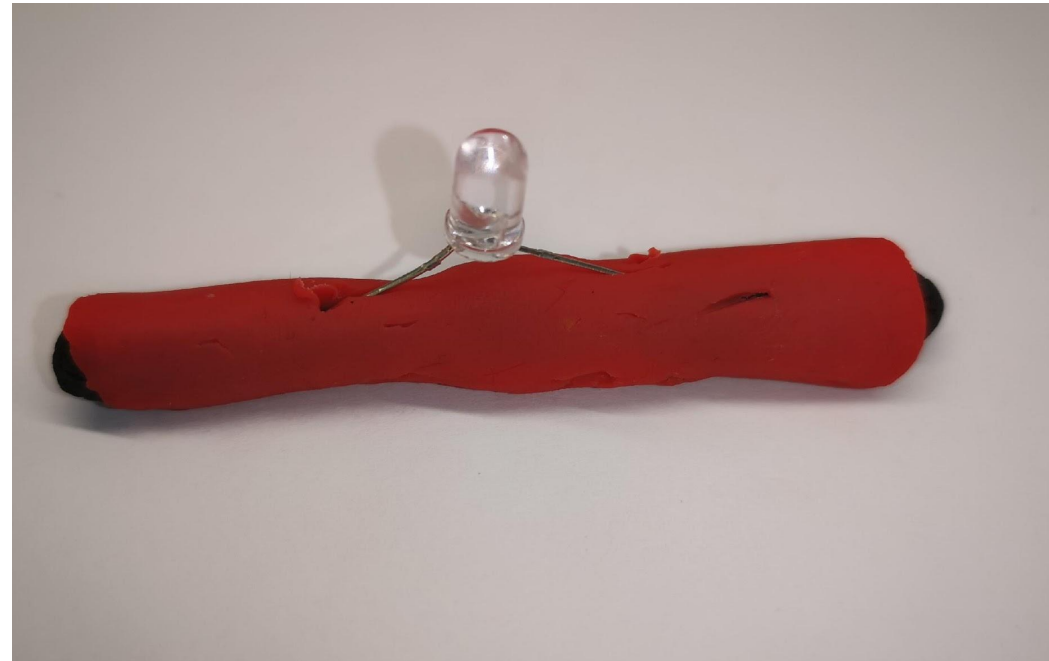
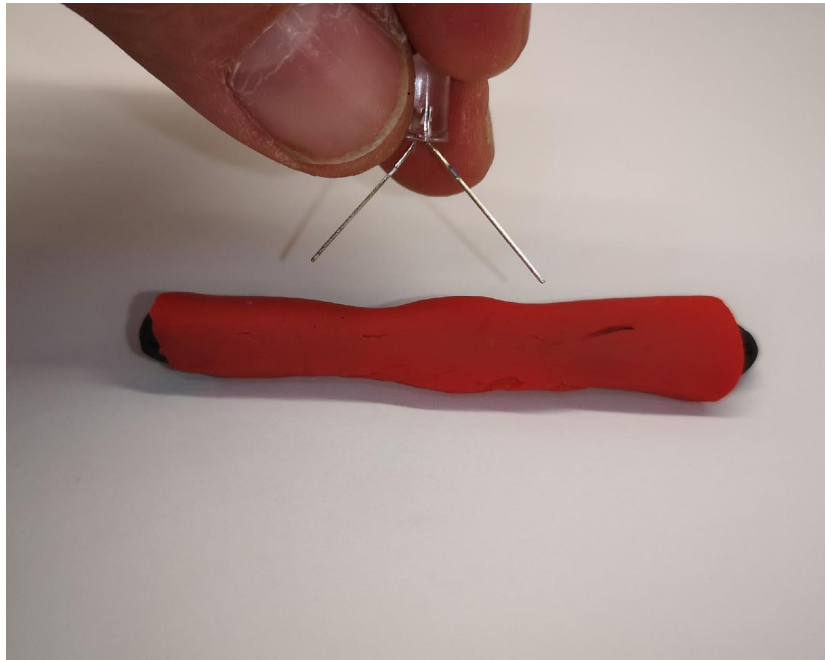

## LED CIRCUIT

Now attach the battery to the battery holder, and embed each wire into one side of the circuit

Each wire must make contact with the conductive Play-Doh hidden inside. Once connected properly, the LED should light up.

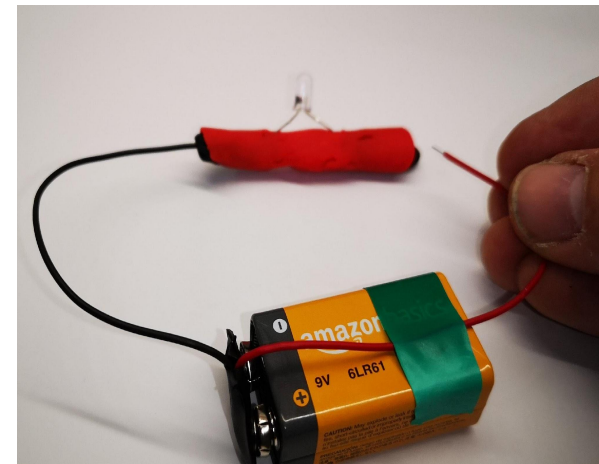
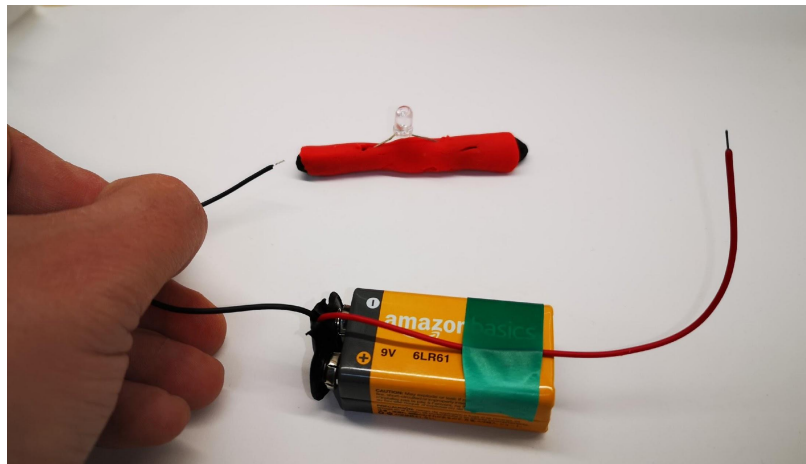



# LEARNING BY DOING:

Let's create a Safe System to Place an LED Inside Our Figure.

## Creativity in motion

Create your favorite character using insulating dough by shaping and modeling the material into the design of your choice.

Add creative details and experiment with features to make it unique!

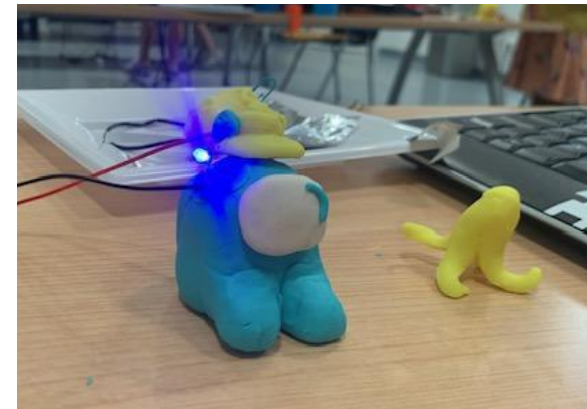

## EXTRA CONTENT

There are two ways to connect LEDs:

1. **In Series:** One LED is connected after another in a single loop.
2. **In Parallel:** The LEDs are connected with all the positive (+) terminals joined together and all the negative (-) terminals joined together.

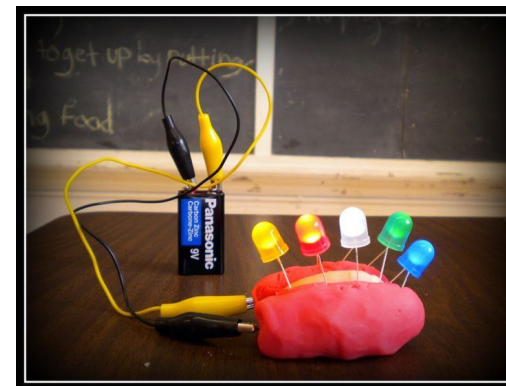
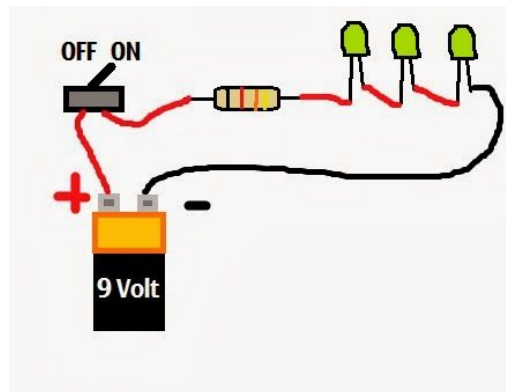

# fab CONNECT her

Future Female  
Innovators In STEAM

## ¡¡GRACIAS!!

The European Commission support for the production of this publication does not constitute an endorsement of the contents which reflects the views only of the authors, and the Commission cannot be held responsible for any use which may be made of the information contained therein

### PARTNER CONTACT

FabLab León | Nuria Robles | [nuria@fablableon.org](mailto:nuria@fablableon.org)

Co-funded by the  
Erasmus+ Programme  
of the European Union

